

4

3

2

1

F

F

E

E

D

D

C

C

B

B

A

A

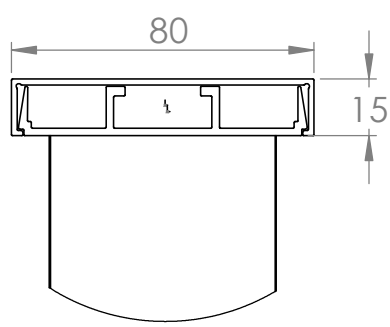
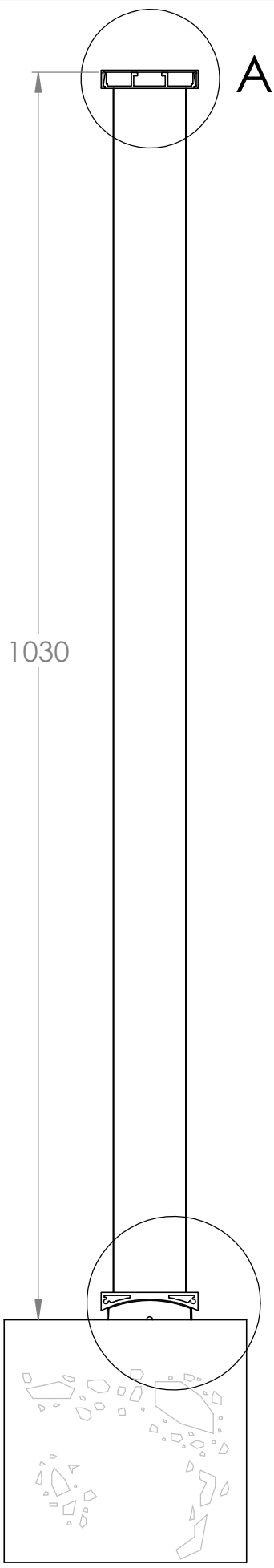

DÉTAIL A
ECHELLE 1 : 2

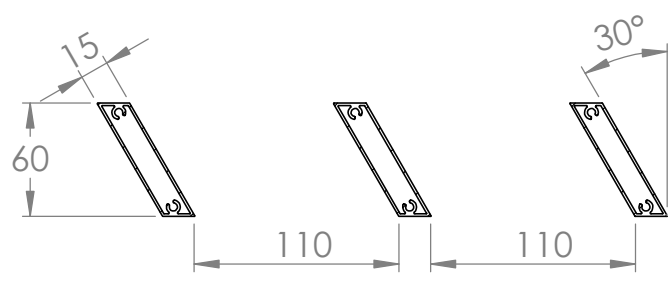
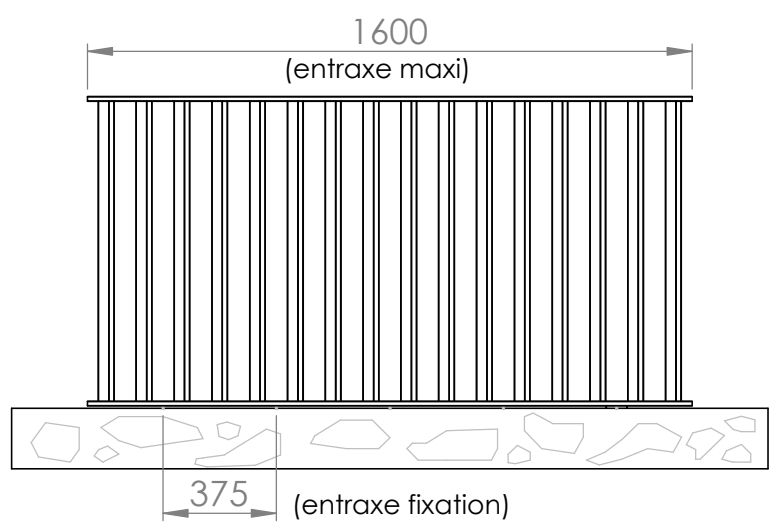

PROFIL BARREAUDAGE

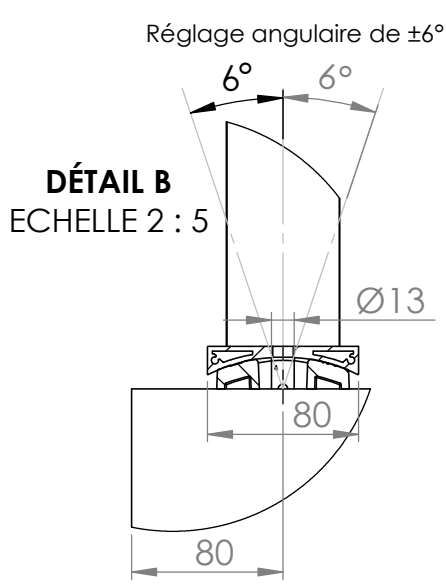

DÉTAIL B
ECHELLE 2 : 5

(Cote préconisée entre bord de maçonnerie et fixation platine)

**DÉTAILS DES CALES
CYLINDRIQUE**

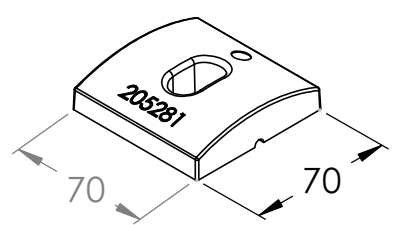

(Fixation tous les 375mm)

Modèle **KAPITALE 30°**

MAJUSKULE
GARDE-CORPS

LES CÔTES SONT EN mm

Goujons d'ancrages non fournis, mais doivent être obligatoirement en inox

4

3

2

1